

# S&K KONSTANTELOS

## Electromechanic Construction Company

- High Frequency Induction Heating Machines
- High Speed Nitrogen Hydraulic Presses
- New Generation Automations



## *New Generation Automations*

Our company after years of development and construction experience on automation systems has available a new range of machinery covering a wide range of needs of its customers.

Are made from special materials properly machined treated without any use of welding. All movable parts are from specific high-strength aluminum and hardness like steel. Because of this special aluminum alloy the mechanical wears minimized because the moving parts are very lightweight and can accelerate and decelerate quickly without requiring too much power from the servo motors.

All electronic-digital parts are placed on the central panel which closes air tightly from the outside space thus ensuring absolute protection and their cleanness. The central panel is equipped with an independent air conditioning system which is controlled by the central industrial computer in order to have a constant temperature while keeping the normal levels of inside humidity.

Through the TFT screen control we can configure, monitor and do all the machine functions. The structure and design of the project is developed so that the user interface be friendly and easy to protect the user even from clumsy operations. The pages and the menu in the screen control can be made to the language who prefers the client.

In order to eliminate jams and have a reliable operation of our automations, the basic logic we follow is that of a continuous step by step monitoring of the mechanical parts confirming that the command received from the central computer executed successfully. With this logic we have complete «cooperation» between electronic-digital and mechanical part of the machine.

In case who not executed a command given by the central computer, it is diagnosed and the machine stops with absolute safety informing us about the case of the failure in the screen control, at the page of errors. Then easily restore the system to its original state by pressing the reset.

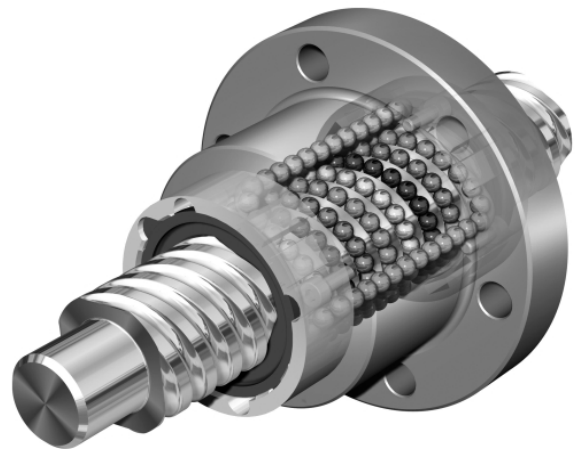

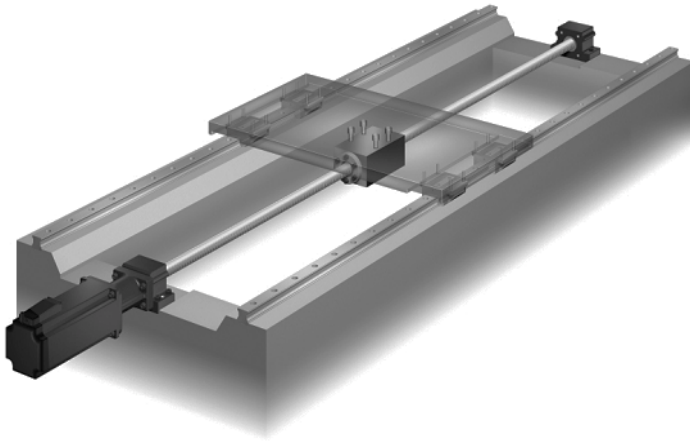

Used latest technology materials from famous brands in the field of robotics such as Siemens, Bosch, ABB, Rittal ets. Powerful quad core processors ensuring ample processing power on the central industrial computer that through the high-speed network communicates with regional cards. The main operating system windows professional as well the system control hardware updated continuously with latest versions.

Our company can undertake and specialized structures beyond the standard models in order to provide integrated solutions to needs of its customers.

For more information and new updates please visit our website or contact us.

**KONSTANTELOS BROS C.O.**  
Electromechanic Construction Company

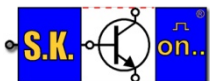

Website: [www.sk-konstantelos.gr](http://www.sk-konstantelos.gr)

Email: [info@sk-konstantelos.gr](mailto:info@sk-konstantelos.gr)

Tel.: +30 2610 670325

Fax: +30 2610 321363

Headquarters: Greece - Patra

Copyright © 2011